

# AOTF-A3-400.650-LR7-TN

# AOTF-A3.5-400.650-MR7-TN

AO POLYCHROMATIC MODULATOR 400-650 nm

## Product Overview

This solid-state AOTF is an electronically tunable bandpass filter for VIS range (400-650 nm). It uses the acousto-optic interaction inside an anisotropic medium (TeO<sub>2</sub>-S). It allows the selection and transmission of several wavelengths from an incoming laser source.

The main advantage of this technique is the total absence of any moving part which leads to a reliable, stable and fast technique for wavelength tuning. The RF frequency applied on the AOTF transducer controls the amplitude of transmitted (filtered in 1st order) wavelength. A complete spectrum analysis can be done by varying the frequency corresponding to the wavelength range. This device has numerous advantages such as its fast rise (several  $\mu$ s), accuracy and its high extinction ratio.

The Main applications are confocal microscopy, life science imaging and many others.



## Features

- Multiline operation
- High colinearity in 1st order
- 405 nm operation
- High separation angle between orders 0-1
- Temperature stabilized
- High power stability / Pointing stability

## Access to your operating manual



## Technical Specifications

Parameter	AOTF-A3-400.650-LR7-TN	AOTF-A3.5-400.650-MR7-TN
Material-Acoustic mode-Velocity	TeO <sub>2</sub> - [S] - 660 m/s	
Number of lines (simultaneously or independently)	2	4
Optical Wavelength range	400-650 nm	
Optical Transmission	> 90%	
Input / Output Polarization	Linear $\perp$ - Linear //	
Active Aperture	3 x 3 mm <sup>2</sup>	3.5 x 3.5 mm <sup>2</sup>
Drive Frequency	74-158 MHz	
Optical Extinction Ratio	>50 dB	
Rise / Fall time	1 $\mu$ s / mm,	
Diffraction Efficiency	> 90 %	
Total Field of View (FOV)	2°	
Separation Angle	$\geq$ 4°	
Chromatic Colinearity	$\leq$ 0.3 mrad	
Spectral Resolution (FWHM)	4 nm @ 400nm, 10 nm @ 550 nm, 16 nm @ 650 nm	2nm @ 400nm, 5nm @550nm, 8 nm @ 650 nm
Max optical power density	5 W/mm <sup>2</sup>	
Temperature stabilization	Type TN (SMC connector)	
Input impedance	Nom 50 $\Omega$	
V.S.W.R.	Nom < 1.2/1	
RF Power per line / Connector	< 0.5 W / SMA (RF)	< 0.3 W / SMA (RF)
Size / Weight	(LxHxh) 70 x 36.6 x 35.8 / 75 g	IN PRO 151
Operating Temperature	+10 to +40 Non condensing	

**Options / On request**

FIBER PIGTAILED VERSION

IN

IN + OUT

WAVELENGTH RANGE

442-700 nm

450-700 nm

**Relative Efficiency versus RF power**

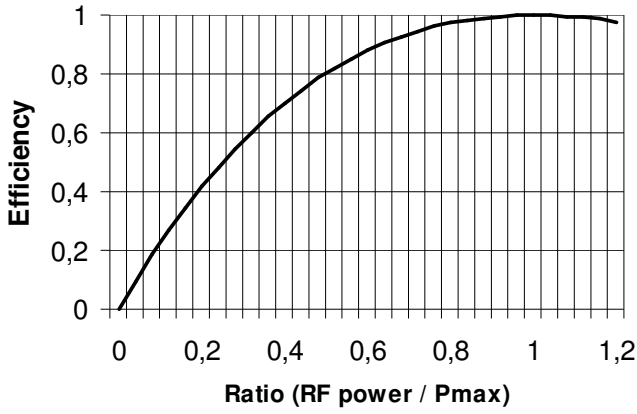

**AO relative Efficiency vs driver MOD IN**

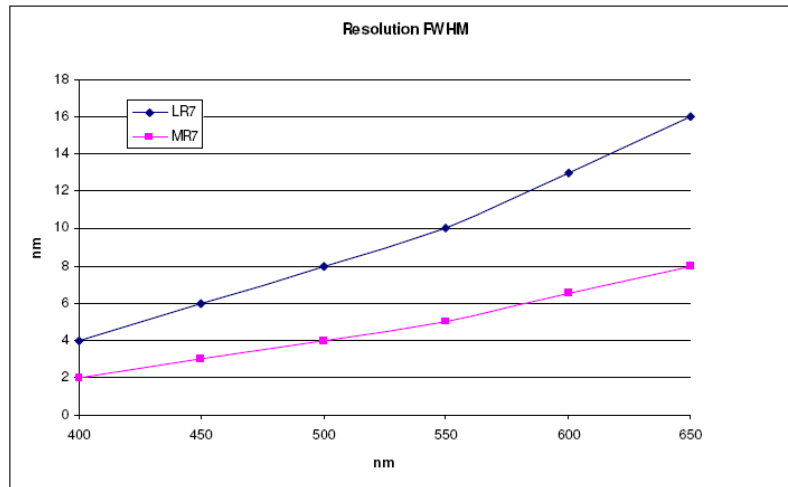
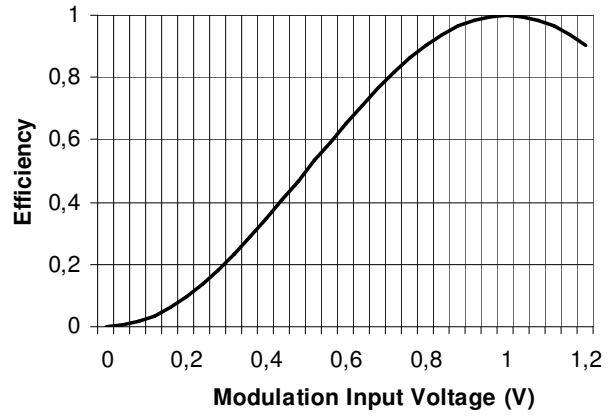

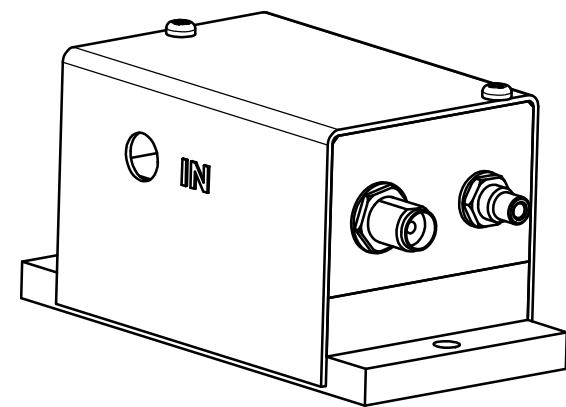

2 Holes  $\varnothing 3,5$   
Through

Bragg Angle Adjust  
 $\varnothing 2,5^{+0,05}$   
 $+0,01$   
Depth 5mm Maxi

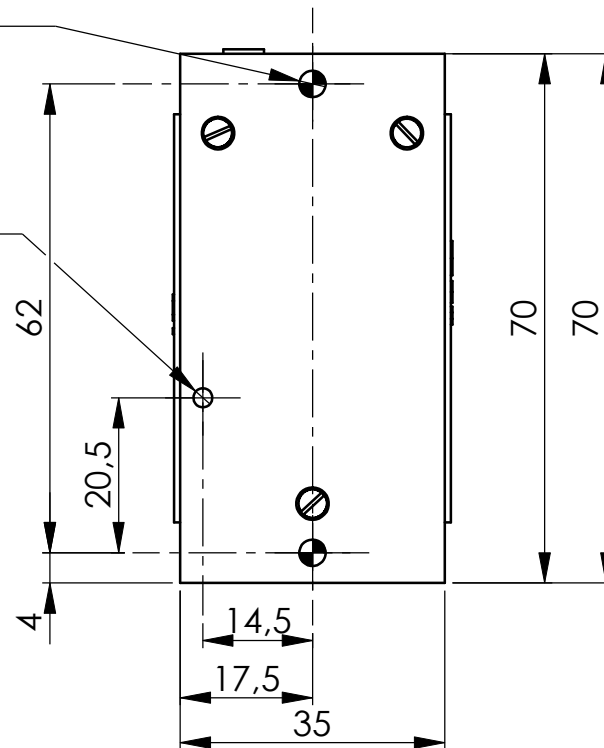

SMA Connector  
RF Input

SMC Connector  
Thermal regulation supply

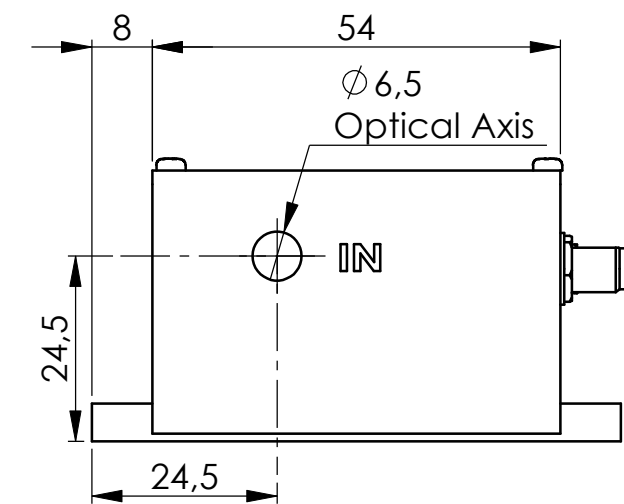
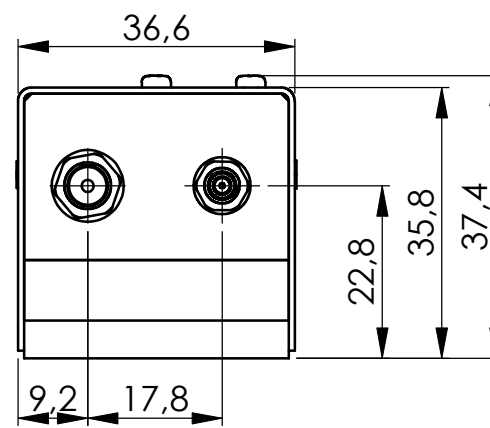
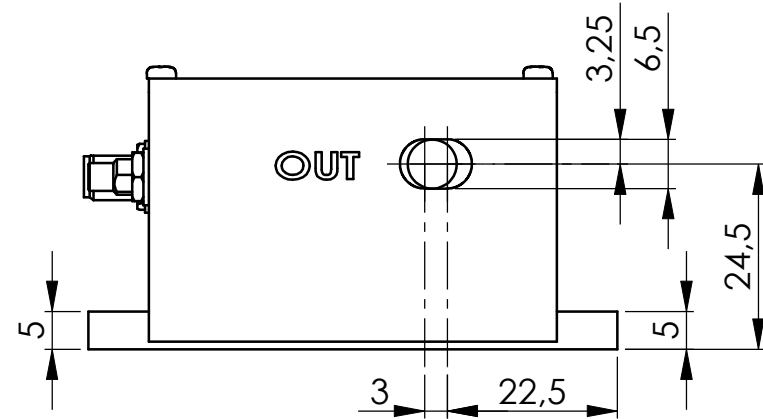
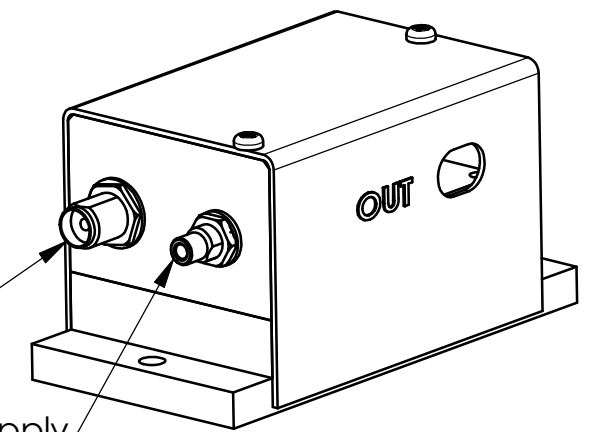

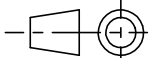
A	15/05/07	E.D	Plan initial / Initial Drawing	
Indice Index	Date	Auteur Author	Modifications	
Conception Design	E.D	PLAN D'INTERFACE / OUTLINE DRAWING		 A.A. SA OPTO-ELECTRONIQUE DIVISION 18, rue Nicolas Appert F-91898 ORSAY tel : 08 11 09 76 76 fax : 01 76 91 50 31
Vérification Checking	L.F			
Tolérance Tolerance	ISO 2768mK	Référence / Reference		
Echelle Scale	1:1	IN-PRO-151		
		Format A3	Ce document est la propriété de A.A.S.A. Il est strictement interdit de reproduire ce document ou une partie sans l'autorisation de A.A.S.A. This document is the property of A.A.S.A. It is strictly prohibited to reproduce this document or a part without the authorization of A.A.S.A.	
			Folio / Sheet 1/1	Indice / Index A