

# MT80-A1-VIS/IR/1064, MT80-A1.5-VIS/IR/1064 MT110-A1-VIS/IR/1064, MT110-A1.5-VIS/IR/1064

## AO MODULATOR/SHIFTER

### Product Overview

These free space modulators are proposed with different aperture sizes and at various wavelength ranges. They have been specially designed for general purpose high speed application such as amplitude modulation. They can also be used as fixed frequency shifters or variable frequency shifters as well as a high speed but low resolution deflector.

### Features

- Large active aperture
- Linear polarization
- High diffraction efficiency

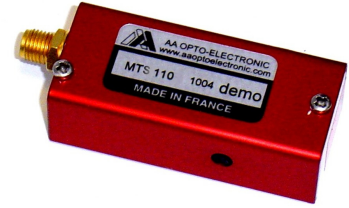

Access to your operating manual

### Technical Specifications

Parameter	MT80-xx	MT110-xx
Material-Acoustic mode-Velocity	TeO <sub>2</sub> [L] - 4200 m/s	
Optical Wavelength range (AR coated)	VIS: 450nm -700 nm IR: 700nm-1100nm 1064: 980nm-1100 nm	
Optical Transmission	> 95 %	
Input / Output Polarization	Linear / Linear	
Active Aperture	1 x 2 mm <sup>2</sup> or 1.5 x 2 mm <sup>2</sup>	
Carrier Frequency / Frequency shift	+/- 80 MHz	+/- 110 MHz
Separation Angle (0-1)	20.3 mrad @ 1064 nm	27.9 mrad @ 1064 nm
Static Extinction Ratio	> 33 dB	
Rise / Fall time	160 ns / mm	
Diffraction Efficiency	> 85 %, nom 90 % with TEM <sub>00</sub> laser beam	
Analog Amplitude modulation bandwidth (-3 dB)	10 MHz, with 0.3 mm beam diameter	
Max optical power density (CW)	VIS: 5 W/mm <sup>2</sup> IR/1064: >10 W/mm <sup>2</sup>	
Input impedance	Nom 50 Ω	
V.S.W.R.	Nom < 1.2/1	
RF Power / Connector	VIS: ≤1W / SMA IR/1064: ≤2W /SMA	VIS: ≤1W / SMA for <b>A1</b> VIS: ≤1.2 W/ SMA for <b>A1.5</b> IR/1064: ≤2 W /SMA
Size / Weight	(LxIxh) 50.9 x 22.4 x 17.3 / 50 g	IN PRO 004
Operating Temperature	+10 to +40 Non condensing	
Storage Temperature	-40 to +50 Non condensing	

### On request

VARIABLE FREQUENCY SHIFT	<input checked="" type="checkbox"/> 80 +/- 15 MHz	Diffraction Efficiency: >80%@ F <sub>0</sub> , >60% over range
	<input checked="" type="checkbox"/> 110 +/- 25 MHz	Diffraction Efficiency: >80%@ F <sub>0</sub> , >60% over range

Rise Time ( $T_r$ ) is beam diameter ( $\Phi$ ) sensitive:

$$T_r = 0.66 \frac{\Phi}{V}$$

Amplitude modulation bandwidth ( $F_{-3dB}$ ) is rise time ( $T_r$ ) sensitive:

$$F_{-3dB} = \frac{0.48}{T_r}$$

Separation angle ( $\Delta\theta$ ) is wavelength ( $\lambda$ ) sensitive:

$$\Delta\theta = \frac{\lambda F}{V}$$

RF power ( $P$ ) is wavelength ( $\lambda$ ) sensitive:

$$\frac{P_1}{P_2} = \frac{\lambda_1^2}{\lambda_2^2}$$

### How to determine your model

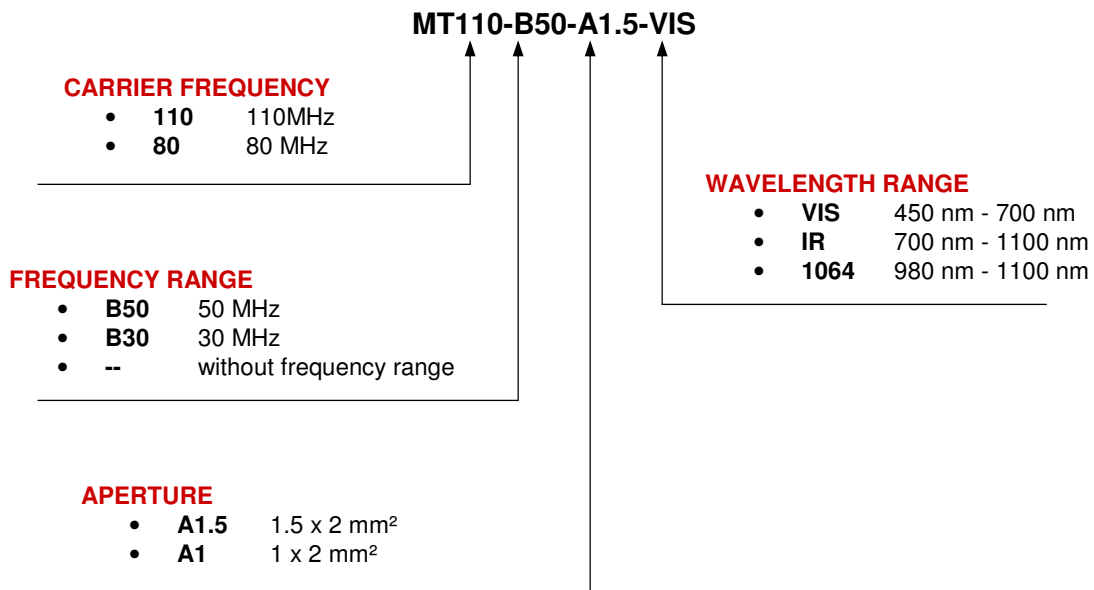

Relative Efficiency versus RF power

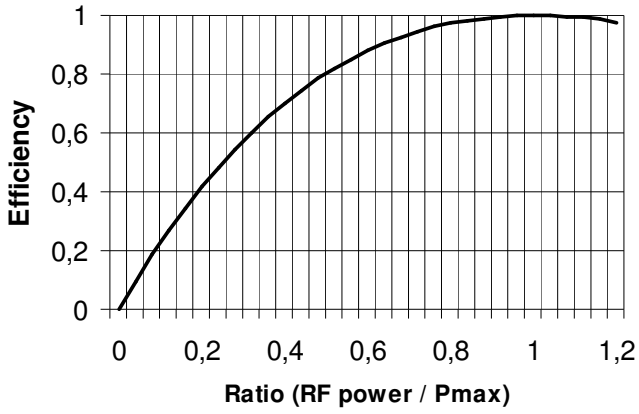

AO relative Efficiency vs driver MOD IN

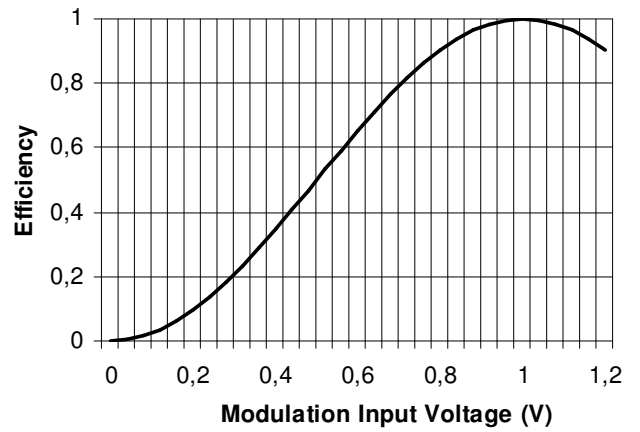

Rise Time (black) / Analog Modulation BW (-3dB) vs Beam diameter

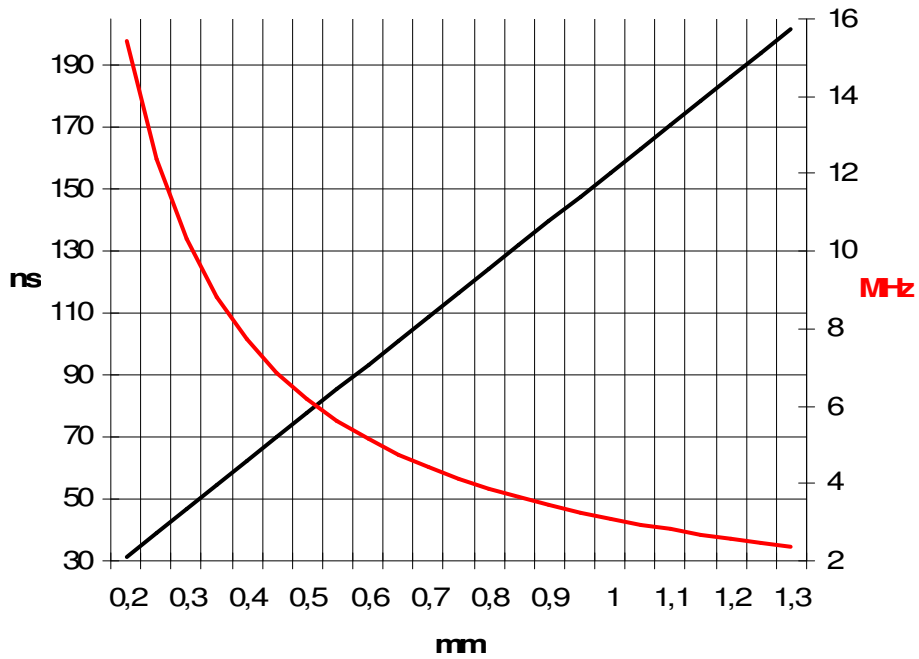

### Relative Efficiency / AOM temporal response

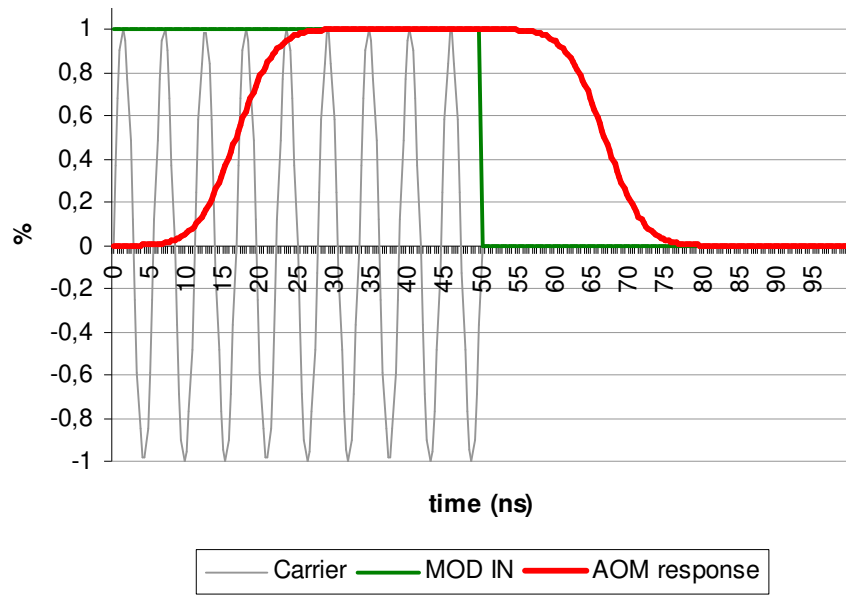

### Relative Efficiency / AOM temporal response 1 MHz with 0,7 mm beam dia

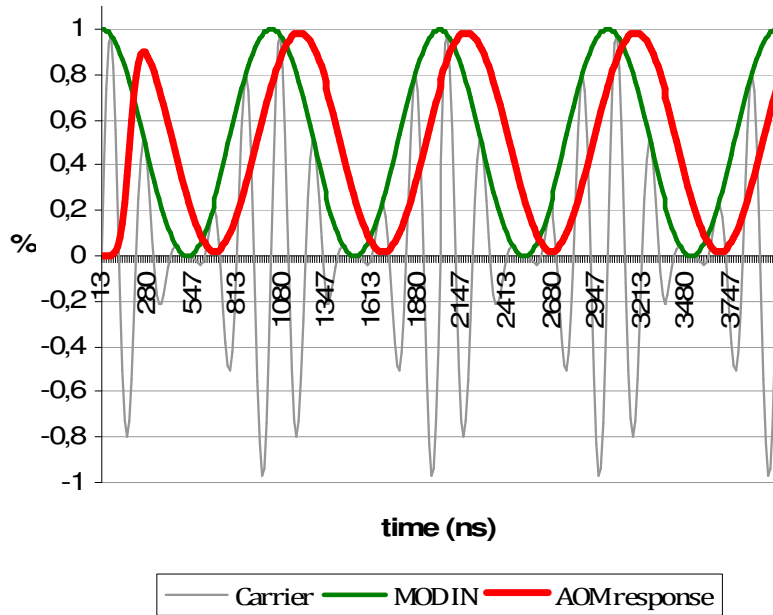

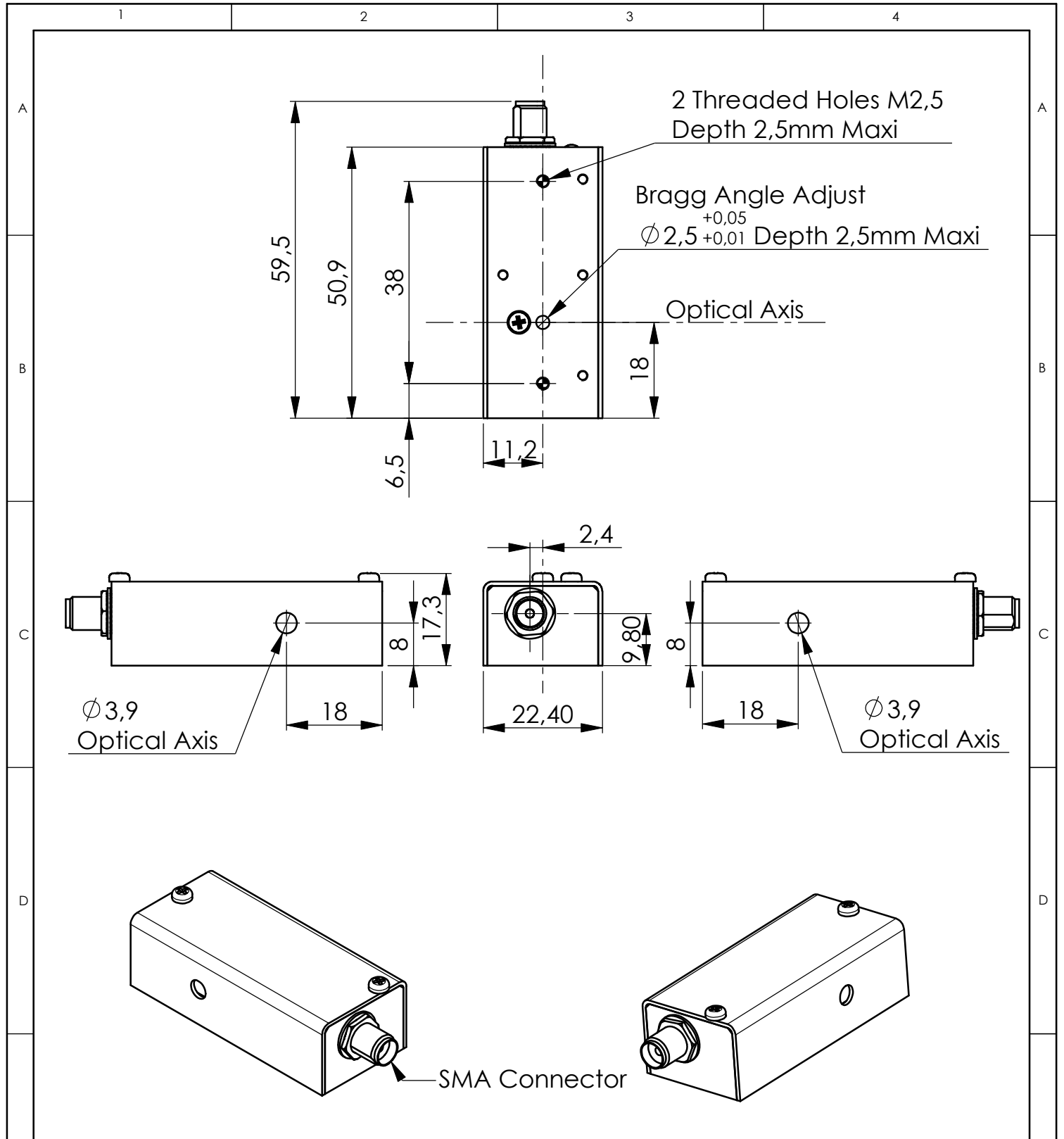

B	18/12/06	E.D	Mise en page
A	15/10/03	OGB	Plan initial / Initial Drawing
Index	Date	Auteur Author	Modifications
Conception Design	E.D	<b>PLAN D'INTERFACE / OUTLINE DRAWING</b>	
Vérification Checking	E.D		
Tolérance Tolerance	ISO 2768mK	Référence / Reference	
Echelle Scale	1:1	<b>IN-PRO-004</b>	
	Format A4	Ce document est la propriété de A.A.SA. Il est strictement interdit de reproduire ce document ou une partie sans l'autorisation de A.A.SA. This document is the property of A.A.SA. It is strictly prohibited to reproduce this document or a part without the authorization of A.A.SA.	
		Folio / Sheet 1/1	Indice / Index B



A.A. SA OPTO-ELECTRONIC DIVISION  
 18, rue Nicolas Appert  
 F-91898 ORSAY  
 tel : 08 11 09 76 76  
 fax : 01 76 91 50 31