

Product Overview

This modulator has been specially designed to operate in the far infrared region most particularly in the wavelength range of 1950-2100 nm. It can be used as an intensity/amplitude modulator as well as a frequency shifter.

Features

- Small rise time
- Linear polarization
- High diffraction efficiency



	Units	Min	Nom	Max
Material-Acoustic mode-Velocity		TeO2 [L] – 4200 m/s		
Optical Wavelength range (AR coated) (λ)	nm	1950		2100
Carrier Frequency / Frequency shift	MHz	+/-80		
Transmission	%	95	98	
Input / Output Polarization		Linear / Linear		
Active Aperture	mm ²	0.4 x 2		
Beam diameter (1/e ²)(φ)	mm	0.2		0.3
Rise/fall time (T _r)	ns	32		48
Analog Amplitude Modulation Bandwidth (-3dB) (F _{-3dB})	MHz			15
Separation Angle (0-1)	mrd	37		38
Static Extinction Ratio	dB	30		
*Diffraction Efficiency (η)	%	65	70	
Optical power density	W/mm ²			10
Input impedance	Ω		50	
V.S.W.R.			< 1.2:1	
RF Power (P)	W		2.2	2.5
Connector		SMA female		
Size	mm ³	50.9 x 22.4 x 17.3		
Weight	g		50	
Packaging		IN PRO 005		
Operating Temperature (non condensing)	°C	+10	+25	+40
Storage Temperature (non condensing)	°C	-40		+65
RoHS Compliance		Yes		
OPTION MT80-B30A0.4-200		Frequency range 80+/-15MHz, Scan angle 14mrd @2μm, Efficiency >50% @2μm over full range		

* Diffraction efficiency is beam diameter and wavelength dependent.

$$T_r = 0.66 \frac{\phi}{v} * F_{-3dB} = \frac{0.48}{T_r} * \Delta\theta = \frac{\lambda F}{v} * \frac{P_1}{P_2} = \frac{\lambda_1}{\lambda_2}$$

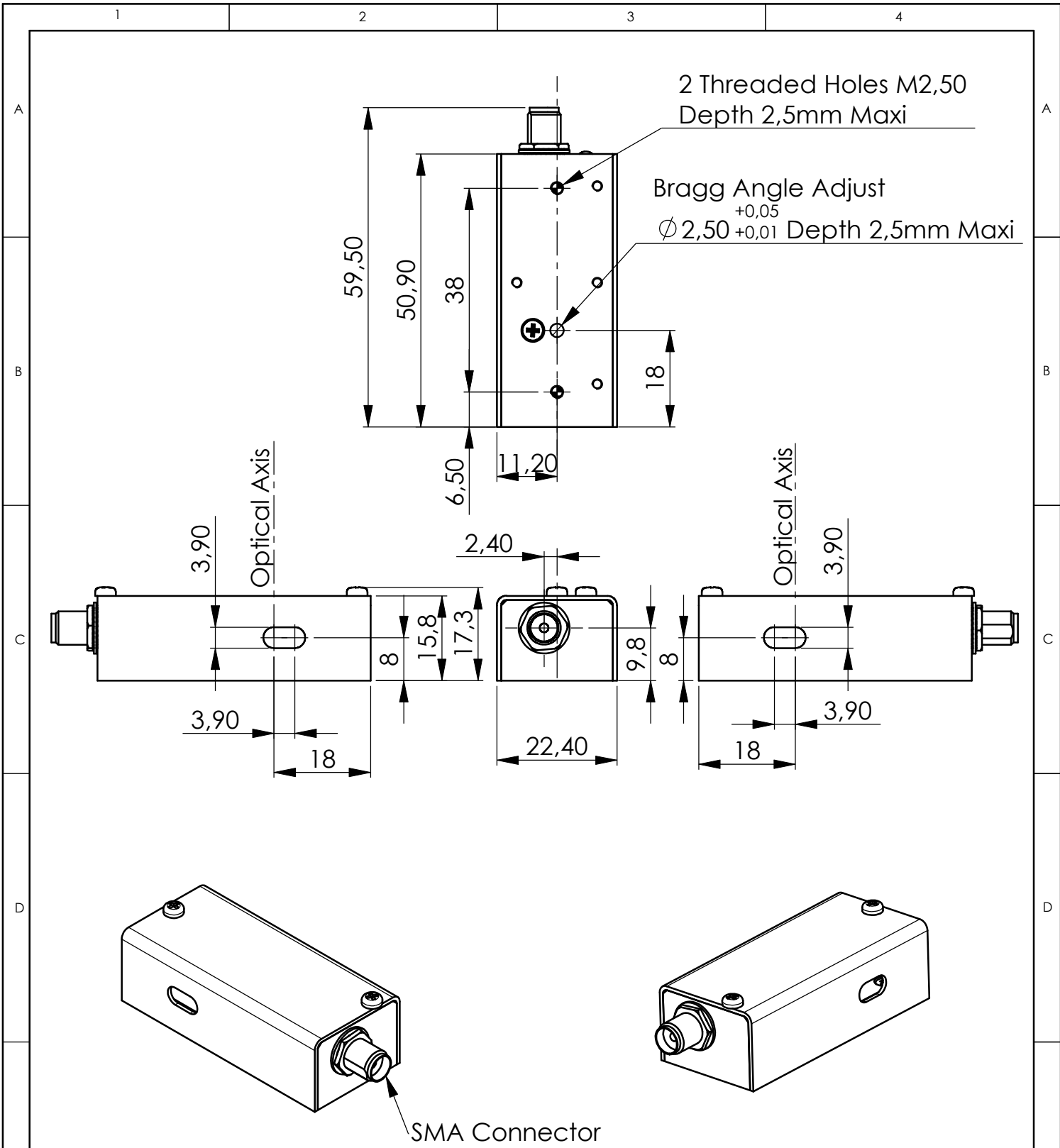

B	18/12/06	E.D	Reprise mise en plan
A	15/10/03	F.C	Plan initial / Initial Drawing
Indice Index	Date	Auteur Author	Modifications
Conception Design	E.D	PLAN D'INTERFACE / OUTLINE DRAWING Référence / Reference IN-PRO-005	
Vérification Checking	L.F		
Tolérance Tolerance	ISO 2768mK		
Echelle Scale	1:1		
		Format A4	Ce document est la propriété de A.A.SA. Il est strictement interdit de reproduire ce document ou une partie sans l'autorisation de A.A.SA. This document is the property of A.A.SA. It is strictly prohibited to reproduce this document or a part without the authorization of A.A.SA.
		Folio / Sheet 1/1	Indice / Index B



OPTO-ELECTRONIC
A.A. SA OPTO-ELECTRONIQUE DIVISION
18, rue Nicolas Appert
F-91898 ORSAY
tel : 08 11 09 76 76
fax : 01 76 91 50 31