

# MQ180-G9-Fio-xx, MT80-G60-Fio-xx, MT200-BGxx-Fio-xx, MT200-Rxx-Fio-xx

AO FIBER PIGTAILED MODULATOR/SHIFTER, VIS RANGE 488-700 nm

## Product Overview

These fiber pigtailed devices are meant to be used for a single wavelength within their range of operation [488-700 nm]. They can be used for intensity modulation, fixed or variable frequency shifting, pulse picking or q-switching. AA offers a complete range with different carrier frequencies, different rise times, input optical power. Moreover, in order to meet most requirements, user can select the fiber type, fiber jacket and fiber connectors among the proposed ones.

## Features

- High speed
- High extinction ratio
- Robust and versatile.



Parameters	MQ180-G9-Fio-xx	MT80-G60-Fio-xx	MT200-BG9-Fio-xx	MT200-BG18-Fio-xx	MT200-BG40-Fio-xx	MT200-R9-Fio-xx	MT200-R18-Fio-xx
Material	SiO2 [L]	TeO2 - [L]					
Optical Wavelength	Any in [488-532] nm		Any in [488-561] nm			Any in [630-700] nm	
IL, Insertion Losses	Nom 3 dB, < 4 dB	Nom 3 dB, < 4 dB	Nom 3 dB, < 4 dB	Nom 2 dB, < 3 dB	Nom 2 dB, < 3 dB	Nom 3 dB, < 4 dB	Nom 2 dB, < 3 dB
Input / Output Polarization	Linear (PM fibres)		Linear (PM fibres) – Random (SM fibres)				
PDL, Polarization Dependence Losses	< 0.5 dB						
Carrier frequency / Frequency shift	+180 or -180 MHz	+80 or -80 MHz	+200 or -200 MHz				
Static Extinction Ratio	> 30 dB, nom 35 dB	> 40 dB, nom 45 dB	> 35 dB, nom 40 dB	> 40 dB, nom 45 dB	> 40 dB, nom 45 dB	> 40 dB, nom 45 dB	> 45 dB, nom 50 dB
Fibre type (SM / PM)	PM	SM or PM					
Jacket type	HYTREL 900 µm or 3 mm PVC or 3 mm stainless steel						
Fibre connectors	FC/APC or Super FC/PC						
Pigtail length	1 meter (IN/OUT)						
Rise/Fall time	9 ns	60 ns	9 ns	18 ns	40 ns	9 ns	18 ns
Analog modulation BW (-3dB)	53 MHz	8 MHz	53 MHz	26 MHz	12 MHz	53 MHz	26 MHz
Max Input laser power (CW)	100 mW@ 532 nm 20 mW@ 488 nm	100 mW	5 mW	20 mW	100 mW	100 mW	400 mW
Input impedance	Nom 50 Ω						
V.S.W.R.	Nom < 1.2/1						
RF Power / Connector	4 W / SMA	< 1.3 W / SMA	< 1.3 W / SMA	< 1.3 W / SMA	< 1.3 W / SMA	< 1.6 W / SMA	< 1.6 W / SMA
Size / Weight	(Lxlxh) 89 x 46.6 x 32.5 mm <sup>3</sup> / 250 g IN PRO 334						

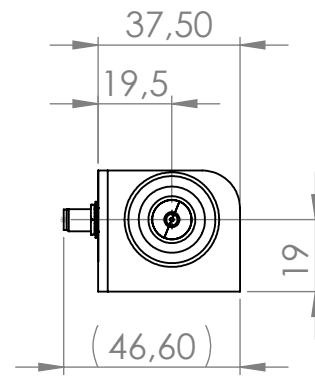
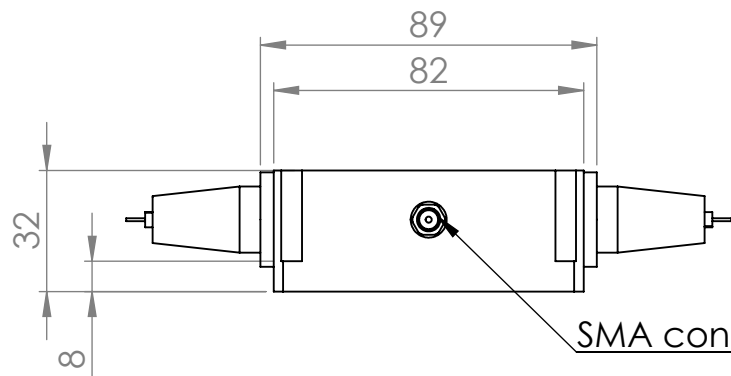

4x FIXING HOLES FOR SCREWS M2.5

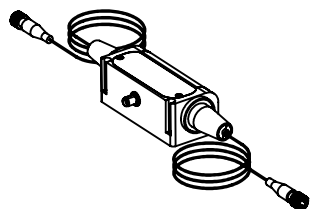
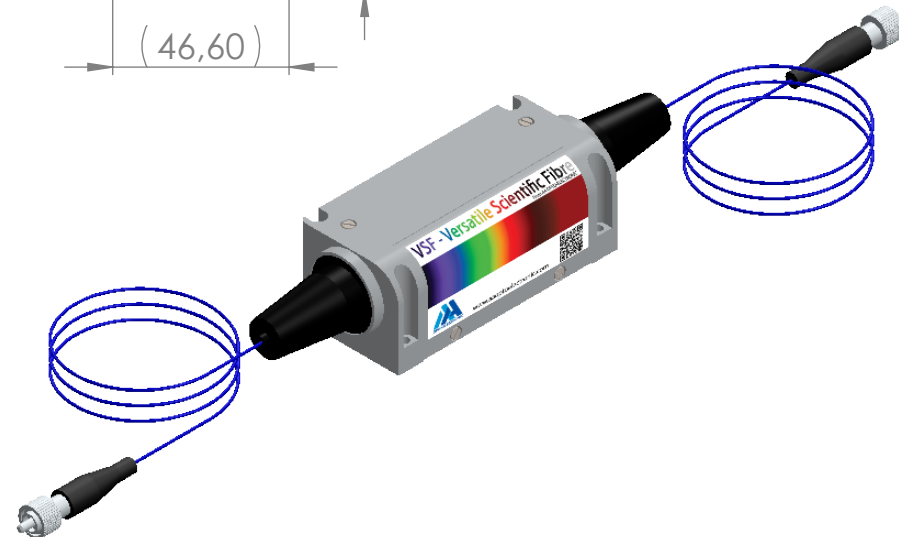
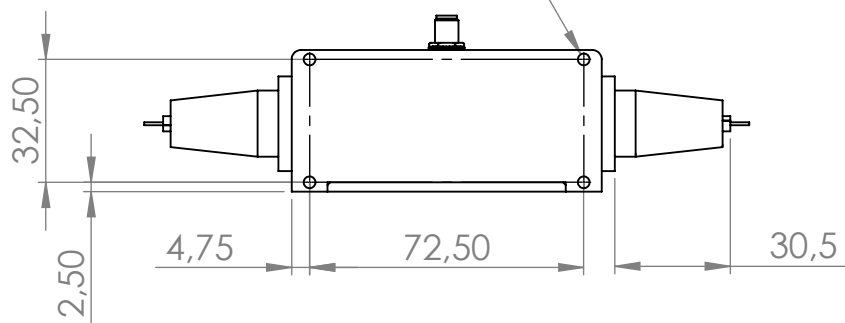

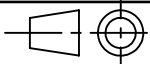
B	28/04/16	G.M	Réhausse fibre de 18 à 19.		
A	17/12/14	G.M	Plan initial / Initial plan		
Indice Index	Date	Auteur Author	Modifications		
Conception Design	GM	Désignation / Designation			
Vérification Checking	YN	PLAN D'INTERFACE			
Tolérance Tolerance	ISO 2768mK	Référence / Reference			
Echelle Scale	1:2	Matière / Material		Traitement / Treatment	Finition / Finish
		Format A4	Ce document est la propriété de A.A.SA. Il est strictement interdit de reproduire ce document ou une partie sans l'autorisation de A.A.SA. This document is the property of A.A.SA. It is strictly prohibited to reproduce this document or a part without the authorization of A.A.SA.		
			Folio / Sheet	1/1	Indice / Index B

A.A. SA OPTO-ELECTRONIC DIVISION  
 18, rue Nicolas Appert  
 F-91898 ORSAY  
 tel : 08 11 09 76 76  
 fax : 01 76 91 50 31